

correlation using the experimentally measured IE (O_{1s}) values given in Table V. The calculated IPs therefore refer to ionization involving removal of an oxygen nonbonding electron. For methyl benzoate, anisole, and benzyl alcohol the calculated (oxygen) IPs are higher than the measured IP, indicating that the lowest IP must involve removal of an electron from the π system of the aromatic ring. However, for benzaldehyde and acetophenone the calculated IPs for ionization at the carbonyl oxygen are in agreement with the measured ionization potentials, indicating that for these two compounds the lowest energy ionization process involves removal of an oxygen nonbonding electron.

Conclusions

The correlations developed between the energies associated with the three modes of ionization, proton addition, core electron ionization, and valence electron ionization have several areas of usefulness as has been illustrated in this paper. Such correlations enable one to estimate the proton affinities of molecules (or functional sites) whose proton affinities cannot be determined experimentally. As an extension of this use, the correlations permit one to deduce the site of protonation to which the established PA refers. The correlations also permit the estimate of molecular ionization potentials involving specific sites in polyfunctional molecules. Although the equations developed here apply only to oxygen-containing compounds, similar relationships undoubtedly are applicable to other heteroatom systems, as has been illustrated elsewhere.¹⁰

Acknowledgments. The authors are indebted to the National Research Council of Canada for financial support and to Professors D. K. Bohme, J. L. Beauchamp, R. T. McIver, and A. Maccoll for communication of results prior to publication.

References and Notes

- (1) Author to whom correspondence should be addressed.
- (2) J. N. Brønsted, *Recl. Trav. Chim. Pays-Bas*, **42**, 718 (1923).
- (3) See for example: (a) V. L. Talroze and E. L. Frankevich, *Zh. Fiz. Khim.*, **33**, 955 (1959); (b) J. L. Beauchamp and S. E. Buttrill, *J. Chem. Phys.*, **48**, 1783 (1968); (c) J. Long and B. Munson, *J. Am. Chem. Soc.*, **95**, 2427 (1973).
- (4) See for example: D. H. Aue, H. M. Webb, and M. T. Bowers, *J. Am. Chem. Soc.*, **98**, 311 (1976), and references cited therein.
- (5) (a) J. P. Briggs, R. Yamdagni, and P. Kebarle, *J. Am. Chem. Soc.*, **94**, 5128 (1972); (b) R. Yamdagni and P. Kebarle, *ibid.*, **98**, 1320 (1976).
- (6) See for example (a) H. I. Schiff and D. K. Bohme, *Int. J. Mass Spectrom. Ion Phys.*, **16**, 67 (1975); (b) D. K. Bohme in "Interactions Between Ions and Molecules", NATO Advances Study Institute, P. Ausloos, Ed., Plenum Press, New York, N.Y., 1975.
- (7) R. L. Martin and D. A. Shirley, *J. Am. Chem. Soc.*, **96**, 5299 (1974).
- (8) D. W. Davis and J. W. Rabelais, *J. Am. Chem. Soc.*, **96**, 5305 (1974).
- (9) T. X. Carroll, S. R. Smith, and T. D. Thomas, *J. Am. Chem. Soc.*, **97**, 659 (1975).
- (10) B. E. Mills, R. L. Martin, and D. A. Shirley, *J. Am. Chem. Soc.*, **98**, 2380 (1976).
- (11) A. G. Harrison, P.-H. Lin, and C. W. Tsang, *Int. J. Mass Spectrom. Ion Phys.*, **19**, 23 (1976).
- (12) J. F. Wolf, R. H. Staley, I. Koppel, M. Taagepera, R. T. McIver, J. L. Beauchamp, and R. W. Taft, *J. Am. Chem. Soc.*, submitted for publication.
- (13) "Ionization Potentials, Appearance Potentials, and Heats of Formation of Gaseous Positive Ions", *Natl. Stand. Ref. Data Ser., Natl. Bur. Stand.*, **No. 26**, 1 (1959).
- (14) G. P. Semeluk and F. P. Lossing, *Can. J. Chem.*, **48**, 955 (1970).
- (15) K. M. A. Refaey and W. A. Chupka, *J. Chem. Phys.*, **48**, 5205 (1968).
- (16) C. D. Finney and A. G. Harrison, *Int. J. Mass Spectrom. Ion Phys.*, **9**, 221 (1972).
- (17) M. A. Baldwin, J. Cottrell, and A. MacColl, private communication.
- (18) P. M. Guyon, W. A. Chupka, and J. Berkowitz, *J. Chem. Phys.*, **64**, 1419 (1976).
- (19) D. K. Bohme, private communication.
- (20) F. C. Fehsenfeld, *J. Chem. Phys.*, **63**, 443 (1975).
- (21) It is obvious from Figure 1 that the data points for CO_2 and O_2 strongly influence the numerical correlations obtained (eq 4 and 6). Omission of these data points results in equally satisfactory correlations, but with no improvement in the correlation coefficients or standard deviations. Further, the proton affinities estimated in the remainder of the paper are not significantly changed. The present correlations have the advantage of showing that CO_2 and O_2 are not exceptions to the PA-IE correlations, although CO is, for reasons discussed in the text.
- (22) S. Forsen and B. Roos, *Chem. Phys. Lett.*, **6**, 128 (1970).
- (23) F. M. Benoit, A. G. Harrison, and F. P. Lossing, *Org. Mass Spectrom.*, in press.
- (24) Y. K. Lau and P. Kebarle, *J. Am. Chem. Soc.*, **98**, 7452 (1976).
- (25) D. P. Martinson and S. E. Buttrill, *Org. Mass Spectrom.*, **11**, 762 (1976).
- (26) D. W. Turner, C. Baker, and C. R. Brundle, "Molecular Photoelectron Spectroscopy", Wiley-Interscience, New York, N.Y., 1970.

Synthesis of Platinum Derivatives of Polymeric and Cyclic Phosphazenes^{1,2}

Harry R. Allcock,* Robert W. Allen, and John P. O'Brien

Contribution from the Department of Chemistry, The Pennsylvania State University, University Park, Pennsylvania 16802. Received August 27, 1976

Abstract: Polymeric and oligomeric, water-soluble anticancer derivatives have been synthesized by the reaction of $[NP(NHCH_3)_2]_n$ or $[NP(NHCH_3)_2]_4$ with K_2PtCl_4 . Two types of compounds were isolated. The first was formed in organic media in the presence of 18-crown-6 ether. The products contained a square planar platinum atom bonded to the nitrogen atoms of the phosphazene skeleton, as verified by the x-ray structure of $Pt^{II}Cl_2[N_4P_4(NHCH_3)_8]$. The second type of derivative was formed in aqueous acid as the salt, $[H_2N_4P_4(NHCH_3)_8]^{2+}[PtCl_4]^{2-}$. The compounds showed tumor inhibitory activity in initial anticancer screening tests. Related derivatives of formula $Pt^{II}Cl_2[N_4P_4(CH_3)_8]$ and $[H_2N_4P_4(CH_3)_8]^{2+}[PtCl_4]^{2-}$ were formed when $[NP(CH_3)_2]_4$ reacted respectively with $PtCl_2$ in organic media or with K_2PtCl_4 in aqueous media.

The anticancer properties of square planar platinum compounds, first reported by Rosenberg,³ have generated considerable interest. However, clinical studies⁴ of platinum complexes, such as *cis*- $Pt^{II}(NH_3)_2Cl_2$ showed that the marked chemotherapeutic effects are accompanied by serious toxic side effects, including bone marrow depletion, damage to the intestinal mucosa, and kidney damage.

We have reasoned that many of these side effects (particularly, kidney damage) may result from the fact that all the platinum derivatives examined to date have been small-molecule complexes that can be excreted rapidly through the semipermeable membranes of the kidney system. Because high polymers cannot pass through semipermeable membranes, the binding of a platinum complex to a polymer should retard the

rate of excretion. The requirements for a suitable system are as follows: (1) the polymer must be water soluble, nontoxic, and provide coordination sites for the binding of platinum; (2) the platinum complex should preferably contain two cis chlorine atoms, since this appears to be a prerequisite for high anticancer activity.

Previous work by Allcock and Kugel, and Allcock, Cook, and Mack, provided the first aminophosphazene high polymers, including poly[bis(methylamino)phosphazene], $[\text{NP}(\text{NHCH}_3)_2]_n$ (I).^{5,6} This polymer had previously been examined for biological compatibility and showed anticoagulant properties. Hence, this macromolecule provided a logical substrate for the binding of platinum complexes. Because the structural analysis of a polymeric complex presents a formidable problem, complexes were also formed with the use of the cyclic tetramers, $[\text{NP}(\text{NHCH}_3)_2]_4$ (II) and $[\text{NP}(\text{CH}_3)_2]_4$ (III), as models for structural analysis.

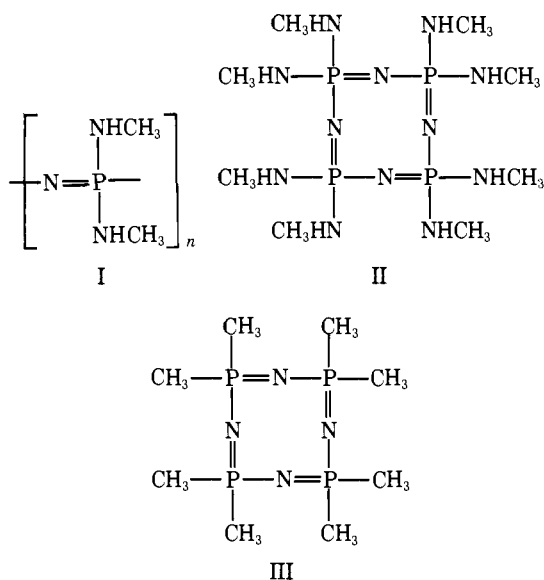

Results and Discussion

The phosphazenes, $[\text{NP}(\text{NHCH}_3)_2]_n$ (I) ($n \approx 15\,000$), $[\text{NP}(\text{NHCH}_3)_2]_4$ (II), and $[\text{NP}(\text{CH}_3)_2]_4$ react with K_2PtCl_4 or PtCl_2 in organic media or with K_2PtCl_4 in aqueous media to yield two types of products—neutral, square planar platinum complexes, such as $\text{PtCl}_2[\text{N}_4\text{P}_4(\text{NHCH}_3)_8]$, or tetrachloroplatinate salts, such as $[\text{H}_2\text{N}_4\text{P}_4(\text{NHCH}_3)_8]^{2+}[\text{PtCl}_4]^{2-}$. Each of these types will be considered in turn.

Reactions of Phosphazenes with K_2PtCl_4 or PtCl_2 in Organic Media. The compounds, $[\text{NP}(\text{NHCH}_3)_2]_n$ and $[\text{NP}(\text{NHCH}_3)_2]_4$, react with K_2PtCl_4 in the presence of 18-crown-6 ether in chloroform to yield yellow colored products with the formulas $(\text{PtCl}_2)_x[\text{NP}(\text{NHCH}_3)_2]_n$ (IV) ($x:n \approx 1:17$) and $\text{PtCl}_2[\text{N}_4\text{P}_4(\text{NHCH}_3)_8]$ (V). The compound, $[\text{NP}(\text{CH}_3)_2]_4$, reacts with the same reagent, but pure samples of $\text{PtCl}_2[\text{N}_4\text{P}_4(\text{CH}_3)_8]$ (VI) could not be isolated. However, this complex (VI) could be prepared pure by the interaction of III with PtCl_2 in benzene.

The polymeric product (IV) was recovered as a water-soluble, flexible thermoplastic, and the two cyclic tetrameric products yielded crystals that were slightly soluble in water. All three products appeared to be stable in aqueous media. Although the composition and structure of the cyclic derivative (V) were unambiguous on the basis of the microanalytical data and x-ray structure analysis, the structure of the polymeric adduct (IV) and the other cyclic derivative (VI) were inferred from the microanalytical data only. However, the ultraviolet-visible spectra of the three complexes were very similar, with a sharp spectral cutoff at 210 nm and a shoulder at 270

nm, and this indicated a similarity of bonding in all three cases.

The methylamino derivatives (IV and V) offered the possibility of coordinative binding to platinum either through the side groups or the skeletal nitrogen atoms. Only the latter alternative exists for the methylphosphazene derivative (VI). An x-ray single-crystal structure determination of (V) has shown unambiguously that the structure involves binding of a square planar platinum atom to the 2:6 *skeletal* nitrogen atoms of the phosphazene ring, as shown in VII.⁷ We believe that this form

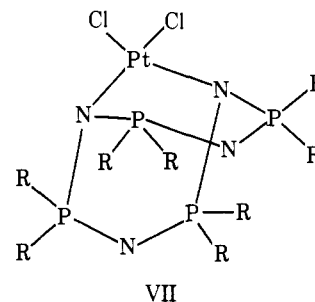

of skeletal bonding to platinum also exists in the polymeric analogue (IV), and in the octamethylcyclotetraphosphazene derivative (VI).

Reactions of Phosphazenes with K_2PtCl_4 in Aqueous Acidic Media. When K_2PtCl_4 was allowed to react with $[\text{NP}(\text{NHCH}_3)_2]_4$ in 0.1 M hydrochloric acid, red, rectangular, plate-type crystals formed immediately. The crystals (VIII) were very slightly soluble in water, but could be recrystallized from boiling 0.1 M hydrochloric acid. Neither the ultraviolet-visible spectrum nor the microanalytical data changed during recrystallization. The ultraviolet spectrum of a solution of VIII in dimethyl sulfoxide was similar to that of K_2PtCl_4 in the same solvent. Moreover, the infrared spectrum closely resembled that of the diprotonated tetramer, $[\text{H}_2\text{N}_4\text{P}_4(\text{NHCH}_3)_8]^{2+} \cdot 2\text{Cl}^-$, which is believed to be protonated at the ring nitrogen atoms.^{8,9} The elemental analysis was consistent with the formula, $[\text{H}_2\text{N}_4\text{P}_4(\text{NHCH}_3)_8]^{2+}[\text{PtCl}_4]^{2-}$. Thus, the structure of this compound is believed to be the one shown in X. Furthermore, octameth-

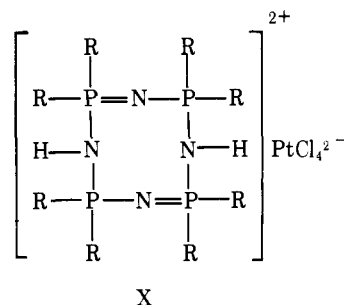

ylcyclotetraphosphazene (III) reacted rapidly with K_2PtCl_4 in aqueous hydrochloric acid to yield red crystals (IX). The spectral and microanalytical results for this complex are consistent with the formula $[\text{H}_2\text{N}_4\text{P}_4(\text{CH}_3)_8]^{2+}[\text{PtCl}_4]^{2-}$. Complex IX is believed to have a structure similar to that of X. A single-crystal x-ray analysis of this product is in progress.

Anticancer Testing. The complexes IV, V, VI, VIII, and IX were tested both by the mouse P388 lymphocytic leukemia survival time test¹⁰ and by the Ehrlich Ascites tumor regression test.¹¹ Compounds IV, V and IX passed the initial P388 test with maximum *T/C* values of 130, 127, and 131, respectively. In this test, a *T/C* value of 125 is considered to be significant. In the Ehrlich Ascites test, compounds IV, VI, and IX were particularly effective with percentage inhibition values of 86.4, 86.3, and 91.4, respectively. However, compound VIII caused 77.8% regression, and compound V 61.3% regression. Of

particular interest is the fact that the charged species, $[\text{H}_2\text{N}_4\text{P}_4(\text{CH}_3)_8]^{2+}[\text{PtCl}_4]^{2-}$ (IX), is an anticancer agent. It had previously been supposed that only neutral platinum complexes were effective as antitumor agents.

Experimental Section

Materials. Hexachlorocyclotriphosphazene, $(\text{NPCl}_2)_3$, was obtained from El Monte Chemical Corp., Pasadena, Calif., as a mixture of the cyclic trimer, tetramer $(\text{NPCl}_2)_4$, and higher oligomers. The trimer was separated from the tetramer and oligomers by fractional vacuum sublimation, followed by recrystallization from *n*-heptane. Methylamine (Matheson) was dried over sodium before use. Tetrahydrofuran (Fisher) was boiled at reflux over lithium aluminum hydride and was freshly distilled from the drying agent before use. Potassium tetrachloroplatinate (Alfa-Ventron, or Pfaltz and Bauer) was used as received. The crown ether, 18-crown-6, (Aldrich) was used as received. Platinum dichloride (Alfa-Ventron) was used as received.

Spectroscopic Measurements. Ultraviolet spectroscopic measurements were performed with the use of a Cary 17 spectrometer. Infrared spectra were obtained with the use of a Beckman 620 grating spectrometer.

Synthesis of $[\text{NP}(\text{NHCH}_3)_2]_4$ (II). Octakis(methylamino)cyclotetraphosphazene was prepared by the reaction of $(\text{NPCl}_2)_4$ with excess methylamine. The product was recrystallized from ethanol [mp 200 °C (lit.¹² 206 °C)].

Synthesis of $[\text{NP}(\text{NHCH}_3)_2]_n$ (I). Hexachlorocyclotriphosphazene, $(\text{NPCl}_2)_3$, was purified for polymerization by vacuum sublimation at 50 °C (0.1 Torr), followed by recrystallization from hot *n*-heptane at a temperature below 75 °C. The first crop of crystals recovered at 25 °C was filtered off, dried in vacuum, and vacuum sublimed. A 150-g portion of this material was placed in a 32.5×3.5 cm constricted Pyrex tube. Air was removed on a vacuum line for 30 min at 0.1 Torr, and the contents were subjected to a melt-freeze-evacuate cycle before the tube was sealed. The tube was then encased in a wire screen jacket and was heated in a thermoregulated oven at 250 °C for 20 h. The mixture of polymer and unchanged trimer was then subjected to vacuum sublimation at 50 °C to remove the trimer. The residual polymer (80 g, 53% conversion) was stored in vacuo until used in the halogen substitution step.

A viscous solution of poly(dichlorophosphazene) (80 g, 0.69 mol-monomer units) in tetrahydrofuran (1800 mL) was prepared. Methylamine (250 mL, 175 g, 5.52 mol) was condensed from a cylinder by means of a cold finger cooled in a dry ice-acetone mixture. The methylamine was dried over sodium spheres. It was then evaporated at 25 °C and recondensed into a flask which contained tetrahydrofuran (1500 mL) at 0 °C. The flask was swept with dry nitrogen. To this vigorously stirred solution was added the solution of poly(dichlorophosphazene) over a period of 2 h. After the addition was complete, the reaction mixture was allowed to warm slowly to 25 °C, and stirring was continued at this temperature for 72 h.

Solvent was then removed from the reaction mixture with the use of a rotary evaporator, and the residue was washed with *n*-heptane and dried in vacuo. Purification was effected by dissolution of the product in water (1000 mL) and dialysis against water through Curtin 077-040 dialysis tubing for 72 h. The solution was concentrated to 250 mL in a rotary evaporator, and the viscous polymer solution was cast on Teflon to yield thin films (30.7 g). These were dried in vacuo at 25 °C for 24 h. The infrared and NMR spectra and physical characteristics of this polymer were identical with those of samples prepared in earlier work.⁶

Synthesis of $[\text{NP}(\text{CH}_3)_2]_4$ (III). This compound [mp 160–161 °C (lit. 163–164 °C)] was prepared by the conversion of tetramethylphosphine disulfide to dimethyltrichlorophosphorane, and reaction of this species with ammonium chloride or ammonia with the use of techniques described previously.¹³

Preparation of *cis*- $\text{Pt}^{\text{II}}(\text{NH}_3)_2\text{Cl}_2$. The method of Kauffman and Cowan¹⁴ was used. K_2PtCl_4 (2.18 g, 5.25×10^{-3} mol) was dissolved in water (35 mL) to which had been added concentrated hydrochloric acid (2.4 mL). Aqueous 6 M ammonia (7.4 mL) was then added, and the solution was refrigerated at 0 °C for 46 h. The light yellow crystals which formed were removed and dissolved in boiling aqueous 0.1 M hydrochloric acid (50 mL). The mixture was filtered and the product was allowed to crystallize at 0 °C for 3 h. The yellow product (0.58 g, 1.94×10^{-3} mol) was isolated in 37% yield. This product was used

primarily for spectroscopic comparison with the phosphazene complexes.

Reaction of $[\text{NP}(\text{NHCH}_3)_2]_n$ with K_2PtCl_4 in Chloroform in the Presence of 18-Crown-6 Ether. A solution of $[\text{NP}(\text{NHCH}_3)_2]_n$ (2.08 g, 2×10^{-2} mol) was prepared in chloroform (100 mL). Solution was complete after a period of 2 days at 25 °C. K_2PtCl_4 (0.83 g, 2×10^{-3} mol) and 18-crown-6 ether (1.06 g, 4×10^{-3} mol) were dissolved in chloroform (100 mL) during a period of 2 days. The two solutions were then mixed, diluted to 300 mL by the addition of chloroform, and allowed to stir at 25 °C for 14 days. After this time, a light yellow, amorphous precipitate (1.78 g) had formed, and this was removed by filtration. A sample of the product (1.24 g) in water (200 mL) was subjected to dialysis against water for 48 h at 25 °C. No evidence was seen for migration of the color. Both the undialyzed and dialyzed samples were prepared as thin films by solution casting on a Teflon support, followed by drying under vacuum at 25 °C. Anal. Calcd for the undialyzed polymer $\text{PtCl}_2[\text{NP}(\text{NHCH}_3)_2]_{17}$: C, 19.9; H, 6.6; N, 34.8; Cl, 3.5; P, 25.7; Pt, 9.5. Found: C, 19.3; H, 7.2; N, 34.5; Cl, 4.5; P, 25.2; Pt (by difference), 9.3. Given the difficulties inherent in the purification and microanalysis of polymers, it seems clear that the platinum is sufficiently strongly bound to the polymer to resist separation and loss during a dialysis experiment.

Synthesis of *cis*-Dichlorooctakis(methylamino)cyclotetraphosphazene-*N,N''* platinum(II), $\text{Pt}^{\text{II}}\text{Cl}_2[\text{N}_4\text{P}_4(\text{NHCH}_3)_8]$. A solution of K_2PtCl_4 (0.83 g, 2×10^{-3} mol) and 18-crown-6 ether (0.96 g, 3.64×10^{-3} mol) in chloroform (100 mL) was prepared. The cyclic phosphazene, $[\text{NP}(\text{NHCH}_3)_2]_4$ (0.84 g, 2×10^{-3} mol), was dissolved in chloroform (100 mL). Both solutions were stirred for 24 h to achieve complete solution and were then mixed. The resultant solution was boiled at reflux for 36 h in an apparatus protected from the atmosphere by a CaCl_2 drying tube, and was then allowed to stand at 25 °C for 2 weeks. The initial crop of yellow crystals (0.22 g) was removed by filtration. The filtrate was evaporated to dryness and the residue was extracted with ether (100 mL). The remaining residue was dried under vacuum and then dissolved in acetone (125 mL). This solution was heated at reflux for 24 h, cooled to 25 °C, and filtered. After 3 days at 25 °C the filtrate yielded a crop of fine yellow crystals (0.16 g), mp 198–200 °C dec. Anal. Calcd for $\text{C}_8\text{H}_{32}\text{Cl}_2\text{N}_{12}\text{P}_4\text{Pt}$: C, 14.00; H, 4.67; N, 24.49; Cl, 10.34; P, 18.05; Pt, 28.45. Found: C, 14.04; H, 4.89; N, 24.60; Cl, 10.14; P, 17.92; Pt (by difference), 28.71.

Reaction of PtCl_2 with $[\text{NP}(\text{CH}_3)_2]_4$ in Benzene Solution. Octamethylcyclotetraphosphazene (III) (0.50 g, 1.7×10^{-3} mol) was dissolved in benzene (125 mL) and 25 mL of solvent were removed by distillation to remove traces of water as an azeotrope.¹⁵ Platinum dichloride (0.44 g, 1.7×10^{-3} mol) was then added and the resultant suspension was heated at reflux for 72 h. The solvent was removed in vacuo and the residue was subjected to sublimation at 100 °C (0.05 Torr) for 10 h. White crystals of III (0.12 g) collected on the cold finger. The nonvolatile residue was then stirred as a suspension in acetone (100 mL) for 2 h, and the mixture was filtered to yield 0.35 g of an insoluble solid and a brown-orange filtrate. *n*-Heptane (75 mL) was added to the filtrate, and slow evaporation of the solvents yielded a precipitate (0.09 g) of a brown product. This was washed with *n*-heptane and dried, mp 210–212 °C dec. Anal. Calcd for $\text{C}_8\text{H}_{24}\text{Cl}_2\text{N}_4\text{P}_4\text{Pt}$: C, 16.97; H, 4.26; N, 9.89; Cl, 12.52; P, 21.88; Pt, 34.45. Found: C, 17.10; H, 4.41; N, 9.79; Cl, 12.35; P, 21.79; Pt (by difference) 34.56. Subsequent column chromatography on neutral alumina from methylene chloride-diethyl ether yielded yellow crystals.

Reaction of K_2PtCl_4 with $[\text{NP}(\text{NHCH}_3)_2]_4$ in Aqueous Hydrochloric Acid. A solution of K_2PtCl_4 (0.42 g, 1.0×10^{-3} mol) in 0.1 M aqueous hydrochloric acid (25 mL) was prepared. To this was slowly added, with stirring, a solution of $[\text{NP}(\text{NHCH}_3)_2]_4$ (0.42 g, 1.0×10^{-3} mol) in 25 mL of 0.1 M hydrochloric acid. After 1 h, the reaction mixture was cooled to 0 °C. The light red crystals were filtered off, washed with methanol, and dried (0.65 g). A portion of the product (0.3 g) was recrystallized from 25 mL of boiling 0.1 M hydrochloric acid. A solution of this material, $\text{H}_2[\text{NP}(\text{NHCH}_3)_2]_4\text{PtCl}_4$, in dimethyl sulfide gave an ultraviolet-visible spectrum very similar to that of K_2PtCl_4 in the same solvent (absorption maximum at 333 nm). Anal. Calcd for $\text{C}_8\text{H}_{34}\text{Cl}_4\text{N}_{12}\text{P}_4\text{Pt}$: C, 12.66; H, 4.51; N, 22.14; Cl, 18.68; P, 16.32; Pt, 25.70. Found: C, 12.60; H, 4.48; N, 21.24; Cl, 18.21; P, 16.65; Pt (by difference), 26.82.

Reaction of K_2PtCl_4 with $[\text{NP}(\text{CH}_3)_2]_4$ in Aqueous Hydrochloric Acid. A solution was prepared of K_2PtCl_4 (0.42 g, 1×10^{-3} mol) in 0.1 M hydrochloric acid (25 mL), and this was mixed with a solution

of $[\text{NP}(\text{CH}_3)_2]_4$ (0.30 g, 1×10^{-3} mol) in 0.1 M hydrochloric acid (25 mL). An immediate, light red precipitate formed. The precipitate was filtered off, washed several times with acetone-water mixtures, and then dried under vacuum. Anal. Calcd for $\text{C}_8\text{H}_{26}\text{N}_4\text{Cl}_4\text{P}_4\text{Pt}$: C, 15.04; H, 4.07; N, 8.77; Cl, 22.20; P, 30.97; Pt, 18.95. Found: C, 15.04; H, 4.24; N, 9.02; Cl, 22.15; P, 30.54; Pt (by difference), 19.01.

Acknowledgment. We thank the Army Research Office for the support of this work.

References and Notes

- (1) This paper is part 30 in a series on phosphorus-nitrogen compounds. A preliminary communication on this work appeared in *J. Chem. Soc., Chem. Commun.*, 717 (1976).
- (2) Part 29 by R. W. Allen and H. R. Allcock, *Macromolecules*, **9**, 956 (1976).
- (3) B. Rosenberg, L. Van Camp, J. E. Trosko, and V. H. Mansour, *Nature (London)*, **222**, 385 (1969).
- (4) B. J. Leonard, *Nature (London)*, **234**, 43 (1971).
- (5) For recent reviews on phosphazene chemistry see (a) H. R. Allcock, "Phosphorus-Nitrogen Compounds", Academic Press, New York, N.Y., 1972; (b) H. R. Allcock, *Chem. Rev.*, **72**, 315 (1972).
- (6) H. R. Allcock, W. J. Cook, and D. P. Mack, *Inorg. Chem.*, **11**, 2584 (1972).
- (7) The details of this x-ray structure determination will be found in R. W. Allen, J. O'Brien, and H. R. Allcock, *J. Am. Chem. Soc.*, following paper in this issue.
- (8) T. Moeller and S. G. Kokalis, *J. Inorg. Nucl. Chem.*, **25**, 875 (1963).
- (9) D. Feakins, W. A. Last, and R. A. Shaw, *J. Chem. Soc.*, **4464** (1964).
- (10) Tests performed at the National Institutes of Health.
- (11) These tests were performed by Dr. Iris H. Hall, Division of Medicinal Chemistry, University of North Carolina. The test data will be described in more detail in a later publication.
- (12) K. John, T. Moeller, and L. F. Audrieth, *J. Am. Chem. Soc.*, **83**, 2608 (1961).
- (13) H. R. Allcock and D. B. Patterson, *Inorg. Chem.*, **16**, 197 (1977).
- (14) G. B. Kauffman and D. O. Cowan, *Inorg. Synth.*, **7**, 239 (1963).
- (15) This procedure resembles one described by J. Dyson (Ph.D. Thesis, 1964, Victoria University of Manchester, pp 93-94) for the reaction of PdCl_2 with $[\text{NP}(\text{CH}_3)_2]_4$.

Crystal and Molecular Structure of a Platinum-Cyclophosphazene Complex: *cis*-Dichloro[octa(methylamino)cyclotetraphosphazene-*N,N'*]platinum(II)^{1,2}

Robert W. Allen, John P. O'Brien, and Harry R. Allcock*

Contribution from the Department of Chemistry, The Pennsylvania State University, University Park, Pennsylvania 16802. Received August 27, 1976

Abstract: The compound, $\text{Pt}^{11}\text{Cl}_2[\text{N}_4\text{P}_4(\text{NHCH}_3)_8]$, is both an antitumor agent and a model compound for the analogous polymeric derivative, $(\text{PtCl}_2)_x[\text{NP}(\text{NHCH}_3)_2]_n$. The x-ray structure of $\text{Pt}^{11}\text{Cl}_2[\text{N}_4\text{P}_4(\text{NHCH}_3)_8]$ has revealed a unique form of bonding in which a square planar platinum atom is bonded to two antipodal *skeletal* nitrogen atoms of the saddle-shaped cyclotetraphosphazene ring. The orientation of the phosphazene ring relative to the platinum atom cannot be explained solely by σ -coordinate bonding or by a π -type interaction. The crystals are monoclinic with the space group $P2_1/n$, and with $a = 10.34$ (2), $b = 15.61$ (4), $c = 14.32$ (4) Å, $\beta = 92.36$ (18)°, $Z = 4$. The Pt-N bond distances are 2.026 (16) and 2.081 (15) Å and the Pt-Cl bond distances are 2.304 (5) and 2.300 (6) Å. The N-Pt-N angle is 87.0 (6)° and the Cl-Pt-Cl angle is 92.9 (2)°. Within the cyclotetraphosphazene unit the P-N bonds flanking the Pt-N units are longer (1.61-1.64 (2) Å) than those at a greater distance from the coordination site (1.57-1.61 (2) Å). The skeletal P-N-P bond angle is marginally wider (128.8 (10)°) at the coordination sites than at the uncoordinated locations (122.2-127.8°). The bonding implications of these results are discussed.

The synthesis of the first platinum-phosphazene complexes was described in the preceding paper.² Several of these compounds have shown activity in preliminary anticancer screening tests, and particular interest was focused on the noncrystalline high polymeric derivative, $(\text{PtCl}_2)_x[\text{NP}(\text{NHCH}_3)_2]_n$. The analogous complex containing a cyclotetraphosphazene ligand, $\text{PtCl}_2[\text{N}_4\text{P}_4(\text{NHCH}_3)_8]$, is itself active as an antitumor agent. Moreover, this compound crystallizes readily and was found to be suitable for x-ray analysis. It was anticipated that the structural information derived from the cyclotetraphosphazene adduct could be used to understand the binding characteristics of the phosphazene high polymer.

Apart from the biomedical implications of this work and the relationship of it to the anticancer activity of platinum compounds in general,^{3,4} considerable fundamental interest revolves around the mode of binding of metal atoms to phosphazene rings. Relatively few metal complexes of cyclophosphazenes have been synthesized.⁵⁻¹⁴ In most (if not all) of these, the metal-ring binding involves a σ -type donation of lone pair electrons from ring nitrogen atoms to the metal. Thus, it was anticipated that the structure solution of

$\text{PtCl}_2[\text{N}_4\text{P}_4(\text{NHCH}_3)_8]$ might provide an added insight into the behavior of phosphazenes as coordinate ligands.

Crystallographic Section

Synthesis of *cis*-Dichloro[octa(methylamino)cyclotetraphosphazene-*N,N'*]platinum(II). The compound, $\text{PtCl}_2[\text{N}_4\text{P}_4(\text{NHCH}_3)_8]$, was prepared by the reaction of octa(methylamino)cyclotetraphosphazene, $[\text{NP}(\text{NHCH}_3)_2]_4$, with potassium tetrachloroplatinate, K_2PtCl_4 , in chloroform solution as described in the preceding paper.²

Collection and Reduction of X-Ray Data. Single crystals suitable for x-ray diffraction examination were grown from acetone solution over several weeks. A clear yellow crystal, $0.24 \times 0.16 \times 0.08$ mm, was chosen and mounted on a eucentric goniometer head. Precession photographs with nickel-filtered copper x radiation ($K\alpha = 1.542$ Å) indicated that the crystal was monoclinic (Laue symmetry $2/m$) with the $h0h$ direction along the spindle axis. Systematic absences were observed for $0k0$ with $k \neq 2n$ and for $h0l$ with $h + l \neq 2n$. These absences led to a choice of a space group as $P2_1/n$. The crystal was transferred to a Syntex four-circle, computer-controlled diffractometer. Ten reflections were centered with molybdenum